

KINEMATIC ANALYSIS OF THE SMA-2 TYPE MECHANISMED SUPPORT USED IN THE JIU VALLEY

**GHEORGHE-BOGDAN URDEA¹, AURELIAN HORIA NICOLA²,
BOGDAN IOAN MARC³**

Abstract: Dimensioning mistakes in mining supports have resulted in numerous victims, major accidents, important mining risks, expensive technologies, the closure of mines and even the abandonment of some basins. Practically, mining support was worked to the limit, the increase of its resistance being determined only by surprises or other damages. Recently, several trends and methods of approaching the dimensioning of mechanized supports have been noted. In this work, we studied the kinematics of the SMA-2 type mechanized support frequently used in the Jiu Valley, focusing on the geometry in the vertical and transverse planes.

Keywords: mechanized support, kinematics, vertical plane, transverse plane

1. INTRODUCTION

Strictly mining, technological aspects, being most of the time difficult to solve, led to the secondary place of the study of the mechanical construction to support the abattoir. Moreover, the geological-mining conditions being favorable, solutions were found that responded well to practical problems. When it was switched to much harder conditions, two negative effects were found on the old machine; the excessive increase in weight and a constructive complication that greatly increases the cost of mechanized complexes. These aspects, correlated with other unfavorable conditions, have led to a tendency of the ordinary miner to reject complex mechanization, on account of which the excessive increase in the cost of production is blamed. We believe that part of the blame for this reality must be attributed to the lack of concern for improving the actual mechanical construction.

We believe that, under the pressure of the multitude and severity of mining problems, the mining specialist was less demanding with the problems considered minor

¹ *Lecturer, Eng. Ph.D., University of Petroșani, urdeagh@yahoo.com*

² *Lecturer, Eng. Ph.D., University of Petroșani, aurelian.nicola@yahoo.com*

³ *Lecturer, Eng. Ph.D., University of Petroșani, bogdanmarc94@yahoo.com*

of the equipment proposed by the designer and manufacturer. The conditions in our country brought more inattention, the high costs of the machines, which normally had to make them uncompetitive, were compensated in other, less technical ways (we worked with planned losses). If the general solutions, as a set of elements, are widely and richly presented in the specialized literature, the construction is little addressed. When there are expositions in this sense, the critical references are so few that they can be neglected

The disadvantages caused by the constructive solutions of the subassemblies of the current mechanized supports are:

- too large thicknesses of the component parts, which leads to the reduction of the useful space in the slaughterhouse;

- the technological solution of the construction made of thick sheet metal, cut with oxygas and welded does not achieve the theoretical geometry that is counted on in the design;

- the lack of a clear concept on the need for a main resistance structure, with sufficient rigidity and the possibility of respecting the geometry in current manufacturing;

- the use of bar elements with curved portions due to kinematic or geometric considerations, but these areas are highly demanded;

- the dimensions of the assemblies delivered by the manufacturer, which must be transported on the galleries to the slaughterhouse, are large and make assembly very difficult;

- the excessive use of the welding assembly method without a strict geometric control and without taking into account the mechanical stresses introduced both locally, in the cords, and as a whole, through the geometric deformations following welding.

In order to improve the constructive solutions, the immediate consequences being the decrease in weight, the transport dimensions and the simplification of assembly, cheaper manufacturing and better mechanical resistance, it is proposed to adopt some concepts that are, moreover, used in other fields

2. SYSTEMS MADE IN ROMANIA

Part of the mechanized supports manufactured in the country are assimilations of foreign machines. However, the assimilation was not done without our specialists contributing to the adaptation to the greatest extent possible to the operating conditions in Romania. One field of coal extraction, especially important in the last years, is that related to coal. The extraction of coal poses special and specific problems for the Romanian deposits, a fact that required a great design effort. For the mines in Jiu Valley, the support that is part of the SMA-2 complex was designed and built (fig. 1.). Main features:

- shield with loosely articulated short beam;
- articulated quadrilateral;
- conveyor on the sole;
- two pillars to the shield.

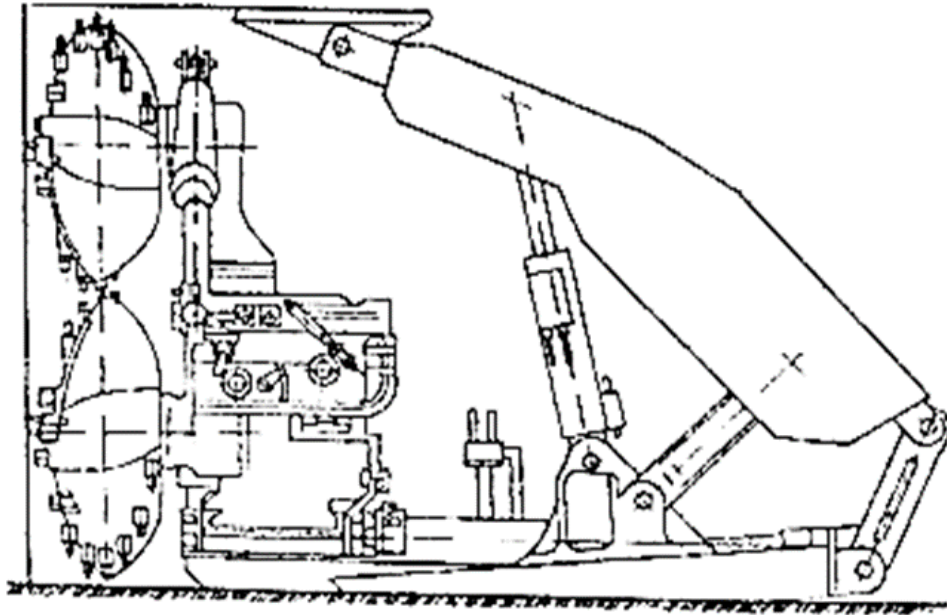

Fig. 1. Support type SMA-2

The machine is adaptable for all coal mines in the country due to: small support pitch (reduces pistoning), adequate hydraulics, relatively low weight (relative to lift). It proved viable in medium conditions of exploitation difficulty.

3. GEOMETRIC SPATIAL MODELING OF THE SUPPORT SYSTEM AND LOADS

For clarity, the problem of defining coordinates, distances and angles will be divided into two:

- defining the geometry in the vertical plane (xOy plane);
- defining the geometry along the cut (on the Oz axis).

3.1 Geometry in the vertical plane

Geometry in the vertical plane the kinematic diagram shown in fig.2. is used. The origin of the axis system is chosen on the axis of the rear joints (of the steering quadrilateral) at the sole, denoted by (1) in fig. 2. (coordinates of joint 1 are: $x=0, y^{\wedge}O$

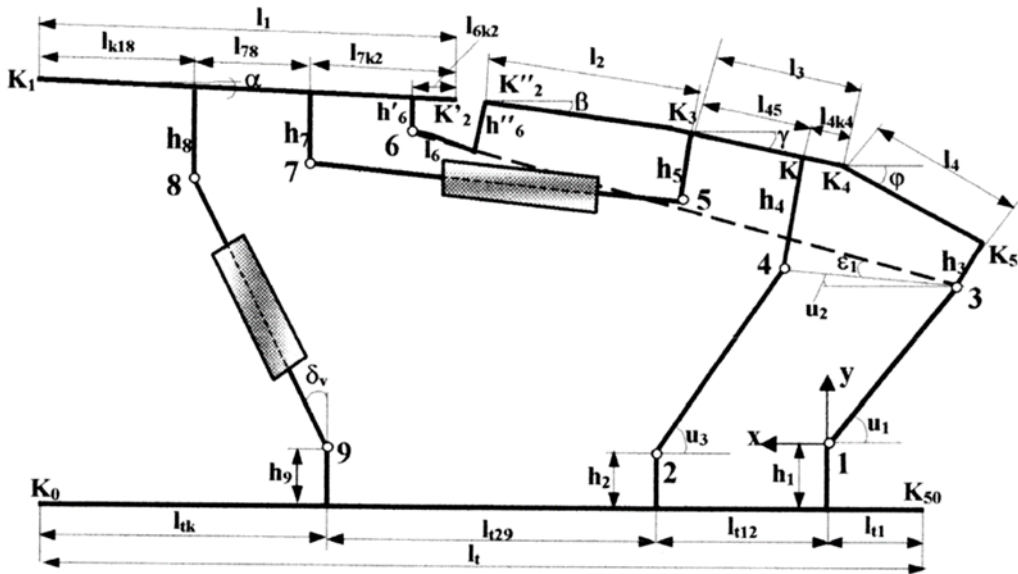

Fig. 2. Kinematic diagram of a mechanized support

The directing quadrilateral is geometrically defined according to the diagram in fig. 3.a. Define the segments on the coordinate axes (fig. 3.), as follows:

$$\begin{aligned}
 OA &= x_2, OD = y_2, OE = l_{13} \cdot \sin u_1, OC = l_{13} \cdot \cos u_1 \\
 EG &= l_{34} \cdot \sin u_2, CB = l_{34} \cdot \cos u_2 \\
 DG &= l_{24} \cdot \sin u_3, AB = l_{24} \cdot \cos u_3
 \end{aligned}
 \tag{1}$$

The geometric relationships between the segments defined above are:

$$\begin{aligned}
 OC + OA &= AB + BC \\
 DG + OD &= OE + EG
 \end{aligned}
 \tag{2}$$

Equations (2) can be rewritten, taking into account (1) and we will have equations (3):

$$\begin{aligned}
 l_{13} \cdot \cos u_1 + x_2 &= l_{24} \cdot \cos u_3 + l_{24} \cos u_2 \\
 l_{24} \cdot \sin u_3 + y_2 &= l_{13} \cdot \sin u_1 + l_{34} \cdot \sin u_2
 \end{aligned}
 \tag{3}$$

the distances between points "i" and "j" are marked with "l_{ij}" (according to fig. 3.a they are l₁₃, l₂₄, l₃₄).

With the notations in fig.2., the distance between joints (3) and (4) on the shield can be calculated, as follows:

$$l_{34} = \sqrt{a^2 + b^2}
 \tag{4}$$

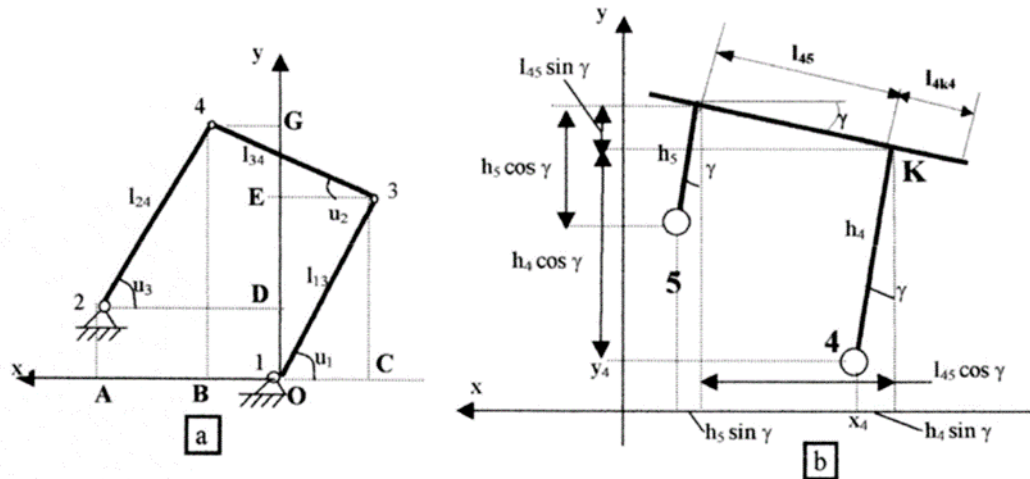

Fig. 3. Kinematic diagram of a mechanized support

The constants "a" and "b" are the difference between the coordinates of joints (3) and (4) horizontally (constant a), respectively vertically (constant b). These constants are calculated by writing the relationships between the projection of some segments horizontally or vertically. The projected segments are (according to fig. 2.): $\overline{4K}$, $\overline{KK_4}$, $\overline{K_4K_5}$, $\overline{K_53}$. The algebraic sum of the horizontal and vertical projections of the respective segments is

$$\begin{aligned} a &= h_4 \cdot \sin \gamma + l_{4K4} \cdot \cos \gamma + l_4 \cdot \cos \varphi - h_3 \cdot \sin \varphi \\ b &= h_3 \cdot \cos \varphi + l_{4K4} \cdot \sin \gamma + l_4 \cdot \sin \varphi - h_4 \cdot \cos \gamma \end{aligned} \quad (5)$$

The distances from the joints numbered with "i" to the contact surfaces with the rock (surfaces in the immediate vicinity of the joint, according to the notations in fig. 2.) were marked with "h". The lengths "l_i" define the size of the straight portions of the contact surfaces with the rock, dimensions measured in the xOy plane. The dihedral angles of the external surfaces of the shield with the horizontal plane were marked with p, y, cp (cf. fig. 2., fig. 4.). The coordinates of the joint (2) are (depending on the constructive dimensions shown in fig. 2.):

$$x_2 = l_{12}, y_2 = h_2 - h_1 \quad (6)$$

The relations (3) between the segments on the coordinate axes (fig.3.) contain two unknowns: the angles "u₂" and "u₃", implicit in the trigonometric functions. If we rewrite the relations only in the cosine function and separate the part containing the unknowns, we will obtain the relations (7), as follows:

$$\begin{aligned} l_{34} \cdot \cos u_2 + l_{24} \cdot \cos u_3 &= l_{13} \cdot \cos u_1 + x_2 \\ l_{34} \sqrt{1 - \cos^2 u_2} - l_{24} \sqrt{1 - \cos^2 u_3} &= -l_{13} \cdot \sin u_1 + y_2 \end{aligned} \quad (7)$$

It is observed that relations (7) represent a system of two equations with two unknowns (the unknowns are $\cos u_2$ and $\cos u_3$). following the operations of substitution and rationalization of the final relation, we arrive at a second degree equation in the unknown " $\cos u_2$ ", whose solution is (8), i.e.:

$$\cos u_3 = \frac{-k_1 k_3 \pm \sqrt{(k_1 \cdot k_2)^2 - (k_1^2 + k_2^2) \cdot (k_3^2 - k_2^2)}}{k_1^2 + k_2^2} \quad (8)$$

Depending on the angle u_1 of the rear bars and the defined constructive parameters, the angles u_2 and u_3 (according to fig. 3.a) are determined from the two projection conditions (3) as follows:

$$u_3 = \arccos \frac{-k_1 k_3 \pm \sqrt{(k_1 \cdot k_2)^2 - (k_1^2 + k_2^2) \cdot (k_3^2 - k_2^2)}}{k_1^2 + k_2^2} \quad (9)$$

$$u_2 = \arccos \frac{k_1 - l_{24} \cdot \cos u_3}{l_{34}}$$

$$\begin{aligned} k_1 &= x_2 + l_{13} \cdot \cos u_1, \\ k_2 &= y_2 - l_{13} \cdot \sin u_1, \\ k_3 &= \frac{l_{34}^2 - k_1^2 - l_{24}^2 - k_2^2}{2 \cdot l_{24}} \end{aligned} \quad (10)$$

The interaction surfaces of the support with the rock are delimited, in the vertical plane, by the " K_i " points, their position being shown in fig. 2. (on the entire support) and in fig. 4. (on the shield). Following the calculations, taking the coordinate system with the origin in the joint (1), according to fig.2., the coordinates of these points are calculated by projecting the segments $\overline{13}$, $\overline{3K_5}$, $\overline{K_5K_4}$, $\overline{K_4K_3}$ etc. on the axes. For points K_5 , and K_4 , following the projections of the segments shown on the coordinate axes, the relations (11) for calculating the coordinates in the vertical plane of these points are obtained, as follows:

$$\begin{aligned} x_{k5} &= -l_{13} \cdot \cos u_1 - h_5 \cdot \sin \varphi, & y_{k5} &= l_{13} \cdot \sin u_1 + h_5 \cdot \cos \varphi \\ x_{k4} &= x_{k5} + l_4 \cdot \cos \varphi, & y_{k4} &= y_{k5} + l_4 \cdot \sin \varphi \end{aligned} \quad (11)$$

Proceed similarly and we can write the relations (12) for calculating the coordinates of the other " K_i " points, as follows:

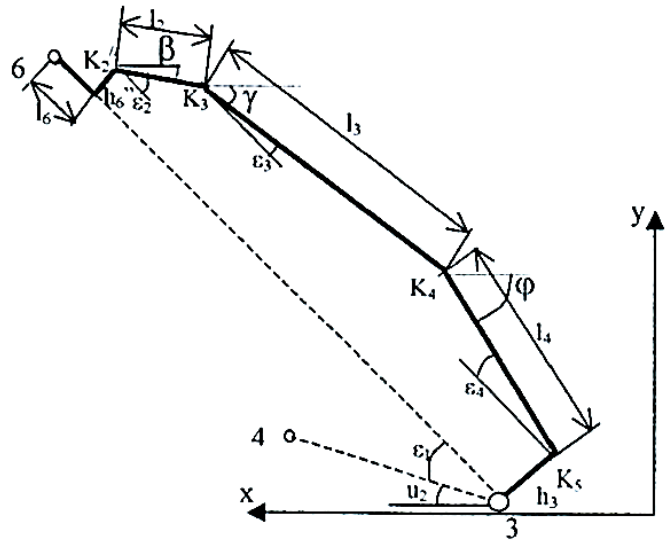

Fig. 4. Kinematic diagram of the support on the shield

$$\begin{aligned}
 x_{k3} &= x_{k4} + l_3 \cos \gamma, & y_{k3} &= y_{k4} + l_3 \sin \gamma, \\
 x_{k2} &= x_{k3} + l_2 \cos \beta, & y_{k2} &= y_{k3} + l_2 \sin \beta, \\
 x_6 &= -l_{13} \cos u_1 + l_{36} \cos(u_2 + \epsilon_1), & y_6 &= l_{13} \sin u_1 + l_{36} \sin(u_2 + \epsilon_1), \\
 x_{k2} &= x_6 - h_6 \sin \alpha - l_{6k2} \cos \alpha, & y_{k2} &= x_6 + h_6 \cos \alpha - l_{6k2} \sin \alpha, \\
 x_{k1} &= x_{k2} + l_1 \cos \alpha, & y_{k1} &= y_{k2} + l_1 \sin \alpha, \\
 x_{k0} &= l_1 + l_{11}, & y_{k0} &= -h_1, \\
 x_{k50} &= -l_1, & y_{k50} &= -h_1
 \end{aligned} \tag{12}$$

The angles of the surfaces on the shield (α , γ , φ), with respect to the horizontal plane, are defined according to the variable u_2 angle (which depends on the variable u_1 angle) and the constructive elements with fixed dimensions of the shield. According to fig.4., the angles with fixed (constructive) values are: ϵ_1 , (between the directions on which the distances l_{34} and l_{36} are measured), ϵ_2 , ϵ_3 , ϵ_3 , (angles between the direction on which the distance l_{36} is measured and the segments $K_{i,i+1}$ that define the three surfaces). depending on the values of the angles "E", the three angles of the shield surfaces will be (for a support position, relations (12)):

$$\beta = u_2 + \epsilon_1 - \epsilon_2, \quad \gamma = u_2 + \epsilon_1 - \epsilon_2, \quad \varphi = u_2 + \epsilon_1 + \epsilon_2 \tag{13}$$

If the angles ϵ_i , are, for a given shield and its given position, in the opposite direction to those defined in fig. 4, they will be entered in relations (13) with negative values.

The angle "α", made by the plane of the beam with the horizontal one, takes

values imposed by the operating regime.

The coordinates of the joints and other important points for the geometric definition of the support in the vertical plane are calculated, from close to close, using distances and angles that have constructive or calculated values (previous relations), "migrating" from one point to another. We will exemplify the way of calculation, showing how to obtain the coordinates of the joint (5) in the xOy plane. According to fig.3.b, the coordinate on the vertical axis "y₅" of the joint (5) is obtained by adding to the coordinate of the joint (4) "y₄" (known), the vertical projections of the distances "h₄", "l₄₅" and subtracting the vertical projection of the distance "h₅" (the distances and angles are in accordance with the notations in fig. 2. and 3.), i.e.:

$$y_5 = y_4 + h_4 \cdot \cos \gamma + l_{45} \cdot \sin \gamma - h_5 \cdot \cos \gamma \quad (14)$$

the horizontal coordinate is obtained in the same way, subtracting from the "x₄" coordinate (known) the projection on the Ox axis of the distance h₄, adding the horizontal projection of the distances l₄₅ and h₅, we obtain the relationship:

$$x_5 = x_4 - h_4 \cdot \sin \gamma + l_{45} \cdot \sin \gamma - h_5 \cdot \cos \gamma$$

In order not to excessively increase the volume of the paper (with simple geometric relations), the equations (15) for calculating all the coordinates (relationships defined similarly to those for articulation 5) will be presented directly, as follows:

$$\begin{aligned} x_1 &= 0, & y_1 &= 0, \\ x_2 &= l_{12}, & y_2 &= h_2 - h_1, \\ x_3 &= -l_{13} \cdot \cos u_1, & y_3 &= l_{13} \cdot \sin u_1, \\ x_4 &= x_2 + l_{24} \cdot \cos u_3, & y_4 &= y_2 + l_{24} \cdot \sin u_3, \\ x_5 &= x_4 - h_4 \cdot \sin \gamma + l_{45} \cdot \cos \gamma + h_5 \cdot \sin \gamma, & y_5 &= y_4 + h_4 \cdot \cos \gamma + l_{45} \cdot \sin \gamma - h_5 \cdot \cos \gamma, \\ x_6 &= x_3 + l_{36} \cdot \cos(u_1 + \varepsilon_1), & y_6 &= y_3 + l_{36} \cdot \sin(u_2 + \varepsilon_1), \\ x_7 &= x_6 - h_6 \cdot \sin \alpha + (l_{7k2} - l_{6k2}) \cdot \cos \alpha, & y_7 &= y_6 - h_6 \cdot \sin \alpha + (l_{7k2} - l_{6k2}) \cdot \sin \alpha, \\ x_8 &= x_7 + l_{78} \cdot \cos \alpha + h_8 \cdot \sin \alpha, & y_8 &= y_7 + l_{78} \cdot \sin \alpha - h_8 \cdot \cos \alpha, \\ x_9 &= x_2 + l_{129}, & y_9 &= -(h_1 - h_9) \end{aligned} \quad (15)$$

It is recalled that the coordinate system originates on the axis of the joints at the sole of the back-left bar (1) (view towards the front), the horizontal axis Ox is positive towards the front, the axis Oy is vertical and positive upwards; the Oz axis is along the abutment, parallel to the front, positive to the right (rear view, facing the front). The lengths and angles that appear in these relationships are constructive quantities (according to figures 2, 3 and 4). The lengths of the corner hydraulic cylinders and their angle with the horizontal are (16):

$$l_{57} = \sqrt{(x_7 - x_5)^2 + (y_7 - y_5)^2}, \quad \omega = \operatorname{arccctg} \frac{y_7 - y_5}{x_7 - x_5} \quad (16)$$

the length of the main cylinders, projected in the vertical plane, is (according to (17)):

$$l_{89} = \sqrt{(x_8 - x_9)^2 + (y_8 - y_9)^2} \quad (17)$$

and the angle between the plane in which their axes are contained and the vertical plane is:

$$\delta_v = \arctg \frac{y_8 - y_9}{x_8 - x_9} \quad (18)$$

3.2. Geometry in the transverse plane

It is necessary to define the coordinates on the Oz axis and the dimensions in the direction of this transverse axis. For simplification and in order not to overlap many elements (difficult to follow), the support will be presented in two projections in the transverse plane yOz. in fig. 5. a front view (from the front) is schematically presented and in fig. 6 a rear view (from the area of the exploited space) is given. The lateral dimensional parameters (along the Oz axis) are highlighted, namely: the distances between the joints (L_i), the width of the sole (L_t) and the beam (L_g), the lateral inclination of the main hydraulic cylinders (δ_l). The joints have the index s - left and d - right, the left and the right side corresponding to the rear view (from the area of the broken rocks). The axis system originates in the 1s (left) joint.

The "z" coordinate of the "K" points, which define the limits of the contact surfaces with the rock, are:

$$\begin{aligned} Z_{K1s} = Z'_{K2s} = Z''_{K2s} = Z_{K4s} = Z_{K5s} &= -0,5 \cdot (L_g - L_1), \\ Z_{K1d} = Z'_{K2d} = Z''_{K2d} = Z_{K3d} = Z_{K4d} = Z_{K5d} &= 0,5 \cdot (L_g + L_1), \\ Z_{K0d} = Z_{K5od} &= -0,5 \cdot (L_t - L_1), \\ Z_{K0s} = Z_{K5os} &= 0,5 \cdot (L_t + L_1) \end{aligned} \quad (19)$$

The z coordinates of the joints are obtained with the relations (20):

$$\begin{aligned} Z_{1s} &= 0, & Z_{1d} &= L_1, \\ Z_{2s} &= 0,5 \cdot (L_1 - L_2), & Z_{2d} &= Z_{2s} + L_2, \\ Z_{3s} &= 0, & Z_{3d} &= L_1, & Z_{4s} &= Z_{2s}, & Z_{4d} &= Z_{2d}, \\ Z_{5s} = Z_{7s} &= 0,5 \cdot (L_1 - L_5), & Z_{6d} &= Z_{6s} + L_5, \\ Z_{6s} &= -0,5 \cdot (L_6 - L_1), & Z_{6d} &= Z_{6s} + L_6, \\ Z_{8s} &= -0,5 \cdot (L_8 - L_1), & Z_{8d} &= Z_{8s} + L_8, \\ Z_{9s} &= 0,5 \cdot (L_1 - L_9), & Z_{9d} &= Z_{9s} + L_9 \end{aligned} \quad (20)$$

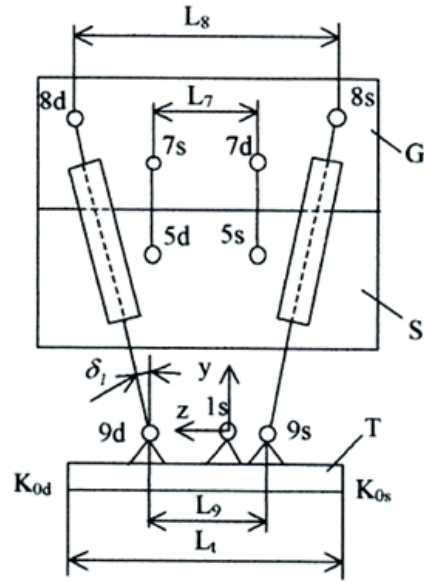

Fig. 5. Schematic front view (from the front)

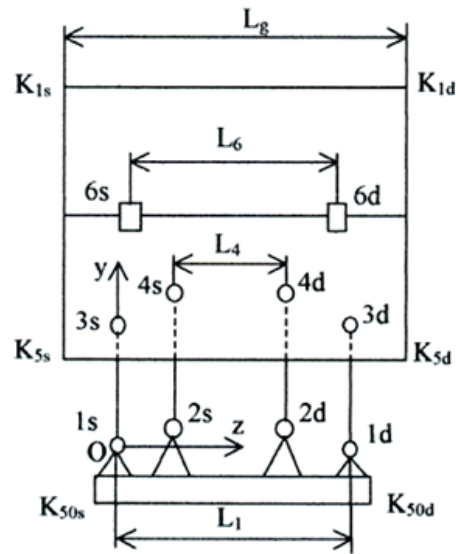

Fig. 6. Schematic view from the back (from the area of the exploited space).

The length of the main cylinders, projected in the transverse plane (yOz) is, according to (21):

$$l_{89d}=l_{89s}=\sqrt{(Z_{9s}-Z_{8s})^2+(y_8-y_9)^2} \quad (21)$$

and the angle made by the longitudinal plane containing the pillars (perpendicular to yOz) with the longitudinal plane xOy is, according to (22):

$$\delta_1=\text{arctg} \frac{(Z_{9s}-Z_{8s})}{(y_8-y_9)} \quad (22)$$

The actual length of the main pillars is calculated with the relation (23):

$$L_{98}=\sqrt{(x_9-x_8)^2+(y_8-y_9)^2+(Z_{9s}-Z_{8s})^2} \quad (23)$$

The director cosines that define the directions of the hydraulic columns are, according to (24):

$$\cos \alpha_x=\frac{X_8-X_9}{L_{98}}, \quad \cos \alpha_y=\frac{y_8-y_9}{L_{98}}, \quad \cos \alpha_z=\frac{Z_8-Z_9}{L_{98}} \quad (24)$$

4. CONCLUSIONS

The hypotheses related to the support-massive interaction allow the presentation of the phenomena only in two dimensions (vertical plane, transversal on the front).

However, if we want to apply them to the mechanical analysis of the support, we are obliged, in order to calculate the loading forces from the ceiling, to introduce the third dimension (along the abutment); this necessity is obvious if we take into account the fact that the vertical loading force is the result of the action of the mining pressure on a surface, this surface having the second dimension along the cut.

So it is necessary, starting from the loading assumptions, to look at the support as a spatial mechanical system, in three dimensions.

The aim of the paper is to design a physical-mathematical model based on which the structure underlying a mechanized slaughter support can be analyzed. Such a model was created, which however shows the inadequacy of the analysis of the phenomena only in one plane, the vertical-transversal one on the front.

The geometry of the structure was defined both in the vertical plane, perpendicular to the front, and in the transverse plane, parallel to the front.

Based on the classical theory of the mechanical equilibrium of the rigid solid, the support structure is not uniquely determined from a mechanical point of view.

So the great difficulty of the mechanical definition of the structure that is the basis of the support is the impossibility of obtaining a strictly (univocally) determined physicomathematical model of it.

Consequently, the mathematical determination of the mechanical parameters specific to the structure can only be done if some physical conditions imposed on the system are defined, in addition to the equilibrium conditions; correlations between

deformations are the most common additional conditions used by those who approach such hyperstatic systems.

REFERENCES

- [1]. **Barczak, T.M., P.,M.** *Design and Operation of Powered Supports for Longwall Mining. Mining Eng., June,1993.*
- [2]. **Dimirache, G., Zamfir, V.** *Ingineria sistemelor mecanice.* Editura Focus, Petroșani 2002.
- [3]. **Fodor, D., Iliș, N., Țiștea, D.** *Mecanizarea în exploatarea miniere la zi.* Editura Tehnică, București, 1978.
- [4]. **Iliș, N.** *Mașini miniere, Lit. I.M. Petroșani,1989.*
- [5]. **Ilincioiu, D.** *Studiul geometric al structurilor de rezistență cu geometrie variabilă folosite la susținerile miniere, Universitatea Tehnică Petroșani, 1991.*
- [6]. **Pop, A.I, Itu, R.B.,** *Loads Transmitted to the Metallic Tower of the Extracting Installation "Puț nou cu schip" Belonging to Petrila Mining Shaft in the Case of the Application of the Safety Brake, Annals of the University of Petrosani, 2013*
- [7]. **Zamfir, V., Iliș, N., Andraș, I.** *Susțineri mecanizate miniere, Ed. Tehnică, București, 1993* 1993.